

WESLO[®] MOMENTUM 750

Model No. WLEL28020

Serial No. _____

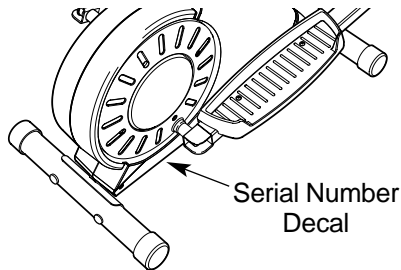

USER'S MANUAL

QUESTIONS?

If you have questions, or if there are missing parts, we will guarantee complete satisfaction through direct assistance from our factory.

TO AVOID DELAYS, PLEASE CALL DIRECT TO OUR TOLL-FREE CUSTOMER HOT LINE. The technicians on our customer hot line will provide immediate assistance, free of charge to you.

CUSTOMER HOT LINE:

1-800-999-3756

Mon.–Fri., 6 a.m.–6 p.m. MST

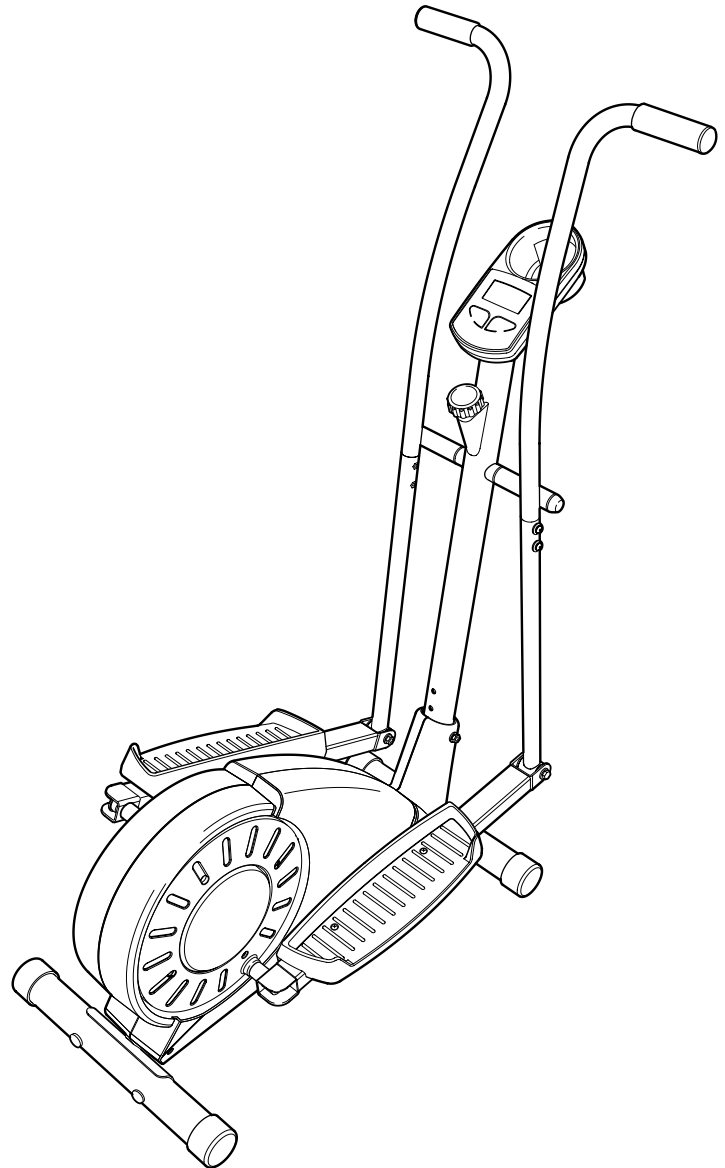

CAUTION

Read all precautions and instructions in this manual before using this equipment. Keep this manual for future reference.



Visit our website at

www.weslo.com

*new products, prizes,
fitness tips, and much more!*



TABLE OF CONTENTS

IMPORTANT PRECAUTIONS3
BEFORE YOU BEGIN4
ASSEMBLY5
HOW TO USE THE ELLIPTICAL CROSSTRAINER9
MAINTENANCE AND TROUBLESHOOTING11
CONDITIONING GUIDELINES13
PART LIST14
EXPLODED DRAWING15
HOW TO ORDER REPLACEMENT PARTSBack Cover
LIMITED WARRANTYBack Cover

IMPORTANT PRECAUTIONS

⚠ WARNING: To reduce the risk of serious injury, read the following important precautions before using the elliptical crosstrainer.

1. Read all instructions in this manual before using the elliptical crosstrainer. Use the elliptical crosstrainer only as described.
2. It is the responsibility of the owner to ensure that all users of the elliptical crosstrainer are adequately informed of all precautions.
3. Place the elliptical crosstrainer on a level surface, with a mat beneath it to protect the floor or carpet. Keep the elliptical crosstrainer indoors, away from moisture and dust.
4. Inspect and properly tighten all parts regularly. Replace any worn parts immediately.
5. Keep children under 12 and pets away from the elliptical crosstrainer at all times.
6. The elliptical crosstrainer should not be used by persons weighing more than 250 pounds.
7. Wear appropriate exercise clothing when using the elliptical crosstrainer. Always wear athletic shoes for foot protection.
8. Always hold the handlebars when mounting, dismounting, or using the elliptical crosstrainer.
9. Keep your back straight when using the elliptical crosstrainer. Do not arch your back.
10. If you feel pain or dizziness while exercising, stop immediately and cool down.
11. When you stop exercising, allow the pedals to slowly come to a stop.
12. The elliptical crosstrainer is intended for home use only. Do not use the elliptical crosstrainer in a commercial, rental, or institutional setting.

⚠ WARNING: Before beginning this or any exercise program, consult your physician. This is especially important for persons over the age of 35 or persons with pre-existing health problems. Read all instructions before using. ICON assumes no responsibility for personal injury or property damage sustained by or through the use of this product.

BEFORE YOU BEGIN

Congratulations for selecting the new WESLO® MOMENTUM 750 elliptical crosstrainer. The MOMENTUM 750 elliptical crosstrainer is an incredibly smooth exerciser that moves your feet in a natural elliptical path, minimizing the impact on your knees and ankles. And the unique MOMENTUM 750 features adjustable resistance and a simple-to-use console to help you get the most from your exercise.



For your benefit, read this manual carefully before using the elliptical crosstrainer. If you have questions after reading this manual, please call our

Customer Service Department toll-free at 1-800-999-3756, Monday through Friday, 6 a.m. until 6 p.m. Mountain Time (excluding holidays). To help us assist you, please note the product model number and serial number before calling. The model number is WLEL28020. The serial number is found on a decal attached to the elliptical crosstrainer (see the front cover of this manual for the location of the decal).

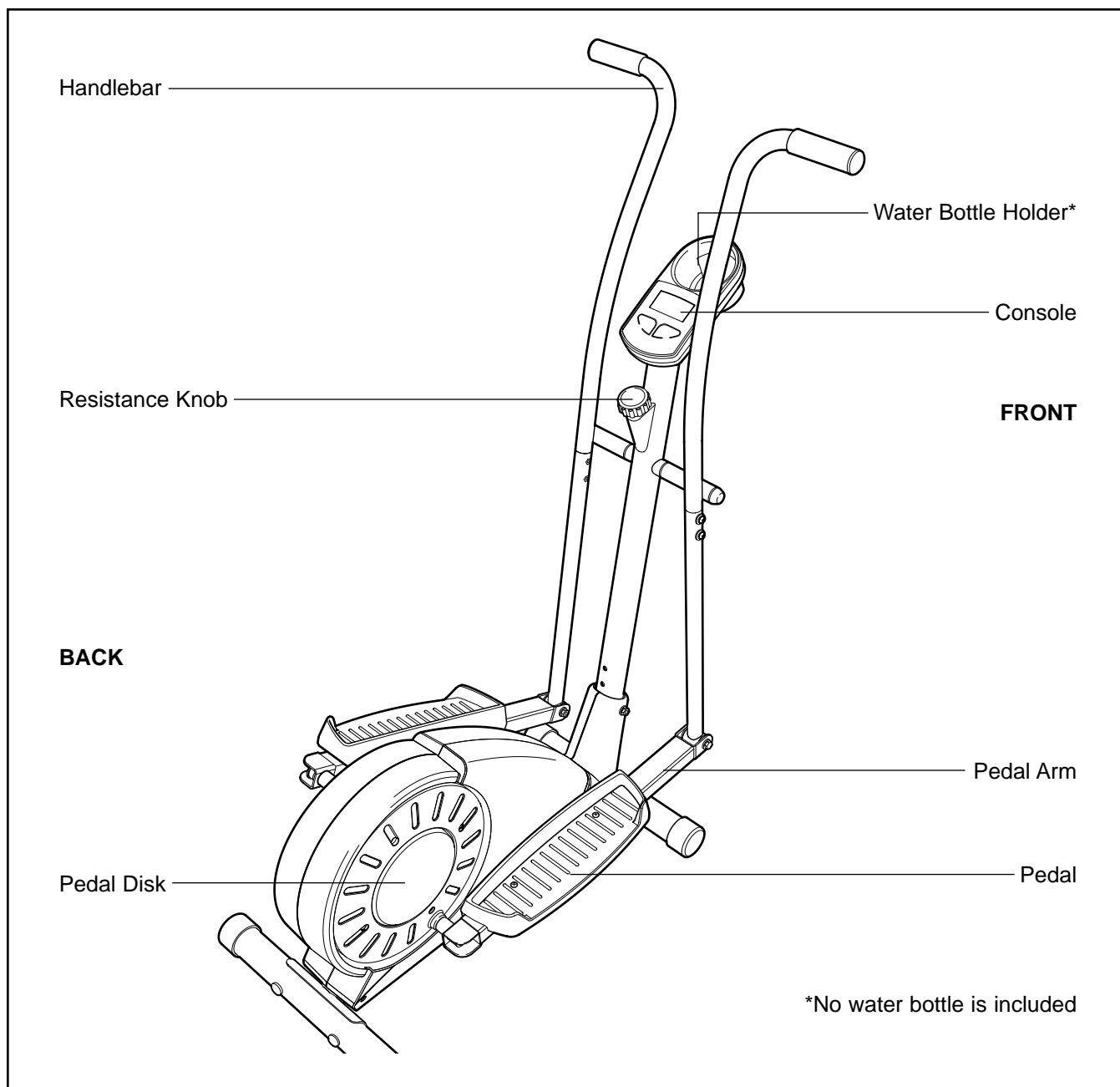
Before reading further, please familiarize yourself with the parts that are labeled in the drawing below.

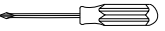

ASSEMBLY

Assembly requires two persons. Place all parts of the elliptical crosstrainer in a cleared area and remove the packing materials. Do not dispose of the packing materials until assembly is completed. **In addition to the included allen wrenches, assembly requires a phillips screwdriver** , **an adjustable wrench** , and **a rubber mallet** .

As you assemble the elliptical crosstrainer, use the drawings below to identify the small parts used in assembly. The number in parenthesis below each drawing refers to the key number of the part, from the PART LIST on page 14. The second number refers to the quantity used in assembly. **Note: Some small parts may have been pre-assembled for shipping. If a part is not in the parts bag, check to see if it has been pre-assembled.**

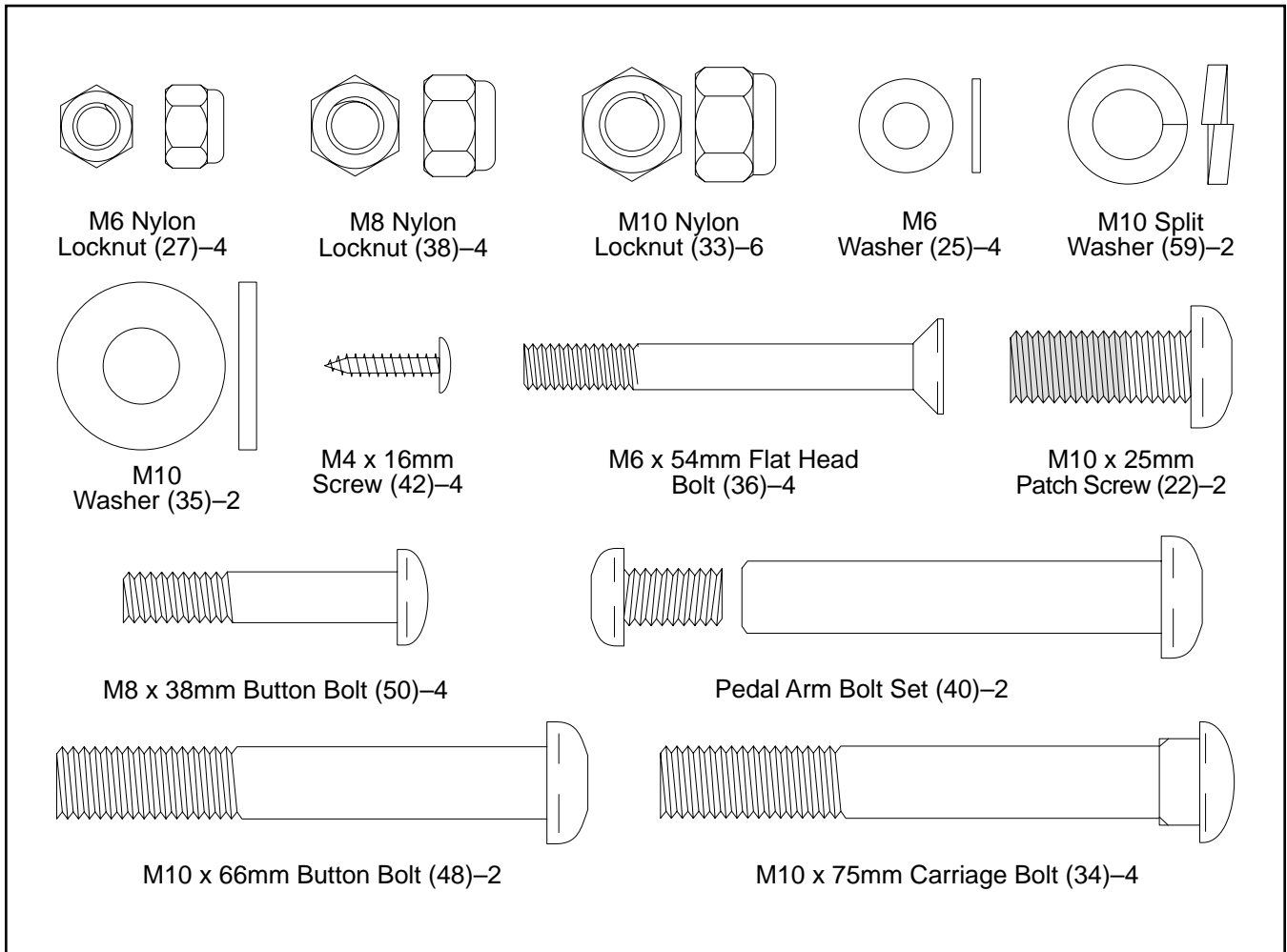

1. Identify the Front Stabilizer (10), which is narrower than the Rear Stabilizer (not shown). While another person lifts the front of the Frame (1), attach the Front Stabilizer to the Frame with two M10 x 75mm Carriage Bolts (34) and two M10 Nylon Locknuts (33).

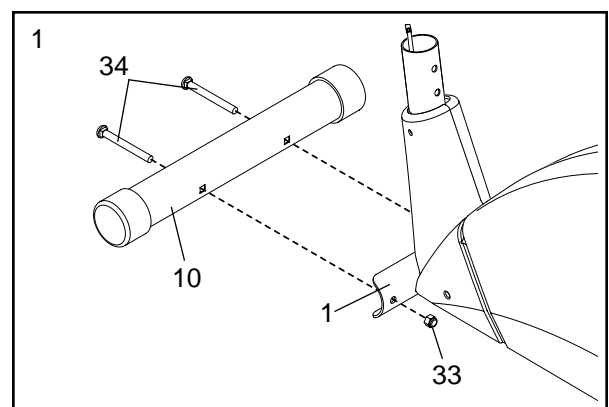

2. While another person lifts the back of the Frame (1), attach the Rear Stabilizer (28) to the Frame with two M10 x 75mm Carriage Bolts (34) and two M10 Nylon Locknuts (33).

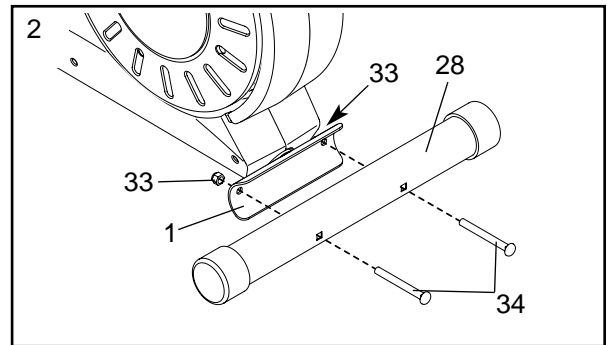

3. The Console (23) requires three “AA” batteries (not included); alkaline batteries are recommended. Insert three batteries into the battery compartment. **Make sure that the batteries are oriented as shown by the diagram inside the battery compartment.**

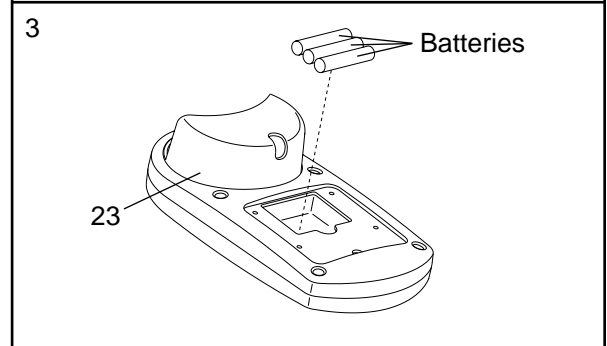

4. While another person holds the Console (23) near the Upright (2), connect the console wire to the Upper Wire (44). Insert the console wire and the Upper Wire into the Upright.

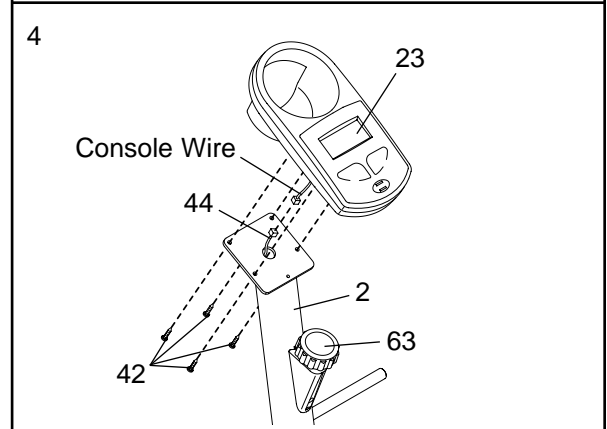

Attach the Console (23) to the Upright (2) with four M4 x 16mm Screws (42). **Be careful to avoid pinching the console wire or the Upper Wire (44).**

Turn the Resistance Knob (63) counterclockwise to the lowest setting before continuing to the next step.

5. While another person holds the Upright (2) near the Frame (1), connect the Upper Wire (44) to the Reed Switch Wire (53).

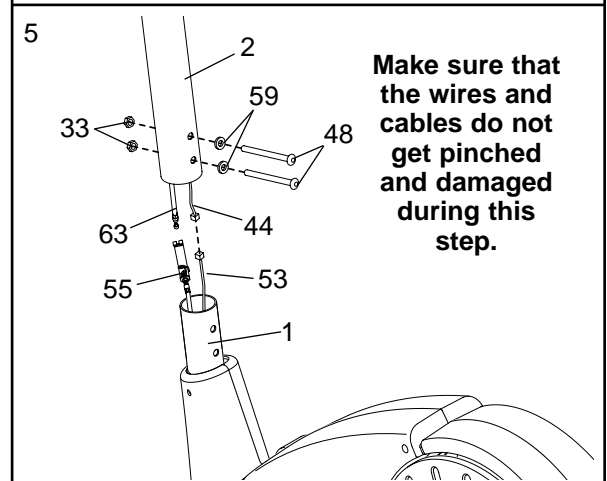

Next, connect the Resistance Cable (63) to the Lower Cable (55) in the following way:

- Refer to drawing A. Pull up on the metal bracket on the Lower Cable (55), and insert the tip of the Resistance Cable (63) into the wire clip inside of the metal bracket.
- Refer to drawing B. **Firmly** pull the Resistance Cable (63) and slide it into the metal bracket on the Lower Cable (55) as shown.
- Refer to drawing C. Using pliers, squeeze together the prongs on the upper end of the metal bracket.

Push the excess cable and wire down into the Frame (1). Slide the Upright (2) onto the Frame. **Be careful not to pinch the wires or cables.** Secure the Upright to the Frame with two M10 x 66mm Button Bolts (48), two M10 Split Washers (59), and two M10 Nylon Locknuts (33). **Do not tighten the Button Bolts yet.**

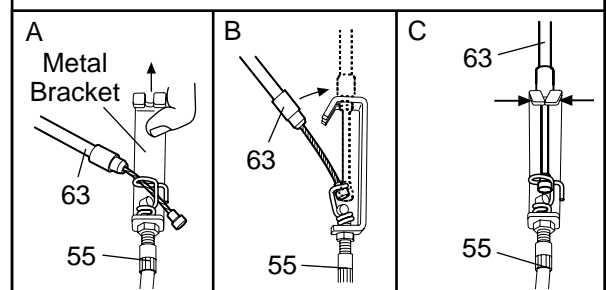

- Identify the Left Handlebar (6), which is marked with a sticker. Insert the Left Handlebar into one of the Handlebar Arms (5); **make sure that the Handlebar Arm is turned so the hexagonal holes are on the indicated side**. Attach the Left Handlebar to the Handlebar Arm with two M8 x 38mm Button Bolts (50) and two M8 Nylon Locknuts (38). **Make sure that the Nylon Locknuts are inside of the hexagonal holes. Do not fully tighten the Button Bolts yet.**

Apply a small amount of the included grease to the left axle on the Upright (2).

Make sure that there are two Small Handlebar Bushings (49) in the Left Handlebar (6). Slide a Handlebar Spacer (47) and the Left Handlebar onto the left axle on the Upright (2) as shown. **Make sure that the Handlebar Spacer is turned so the curved side is facing the Upright.** Tap an Axle Cap (14) onto the axle.

Repeat this step to assemble the Right Handlebar (8) and the other Handlebar Arm (5).

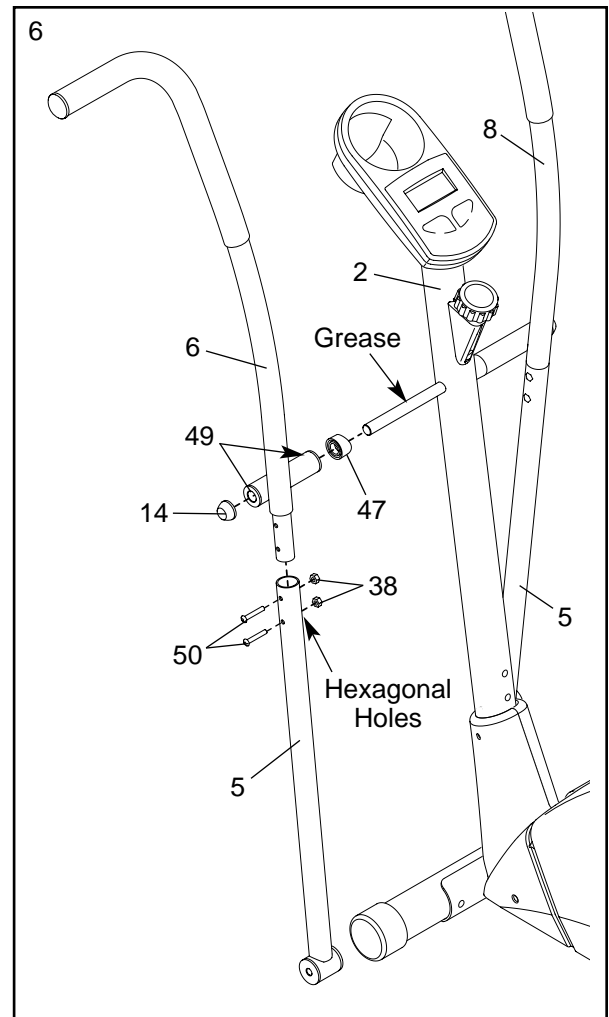

- Identify the Left Pedal Arm (11). Attach a Pedal (13) to the Left Pedal Arm with two M6 x 54mm Flat Head Bolts (36), two M6 Washers (25), and two M6 Nylon Locknuts (27) as shown.

Attach the other Pedal to the Right Pedal Arm (not shown) in the same way.

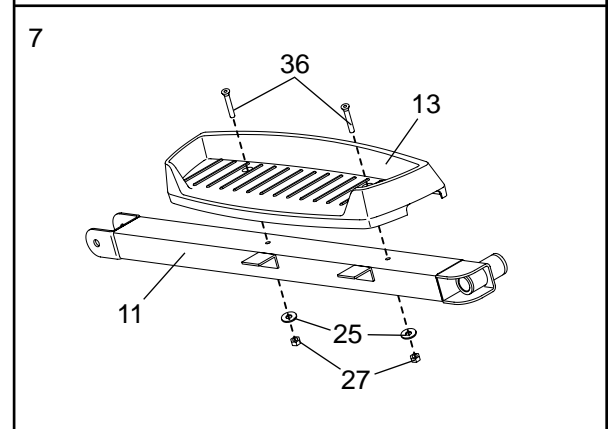

8. Apply a small amount of grease to the axle on the left Disc Crossbar (16). Slide the Left Pedal Arm (11) onto the axle. Slide an M10 Washer (35) onto an M10 x 25mm Patch Screw (22), and tighten the Patch Screw into the axle.

Next, hold the lower end of the left Handlebar Arm (5) inside of the bracket on the Left Pedal Arm (11). Apply grease to a Pedal Arm Bolt Set (40). Attach the Left Pedal Arm to the left Handlebar Arm with the Bolt Set. **Do not overtighten the Bolt Set; the Handlebar Arm must pivot freely.**

Attach the Right Pedal Arm (not shown) to the right side of the elliptical crosstrainer in the same way.

Refer to step 5. Tighten the M10 x 66mm Button Bolts (48) in the Upright (2).

Refer to step 6. Tighten the M8 x 38mm Button Bolts (50) in the Handlebar Arms (5).

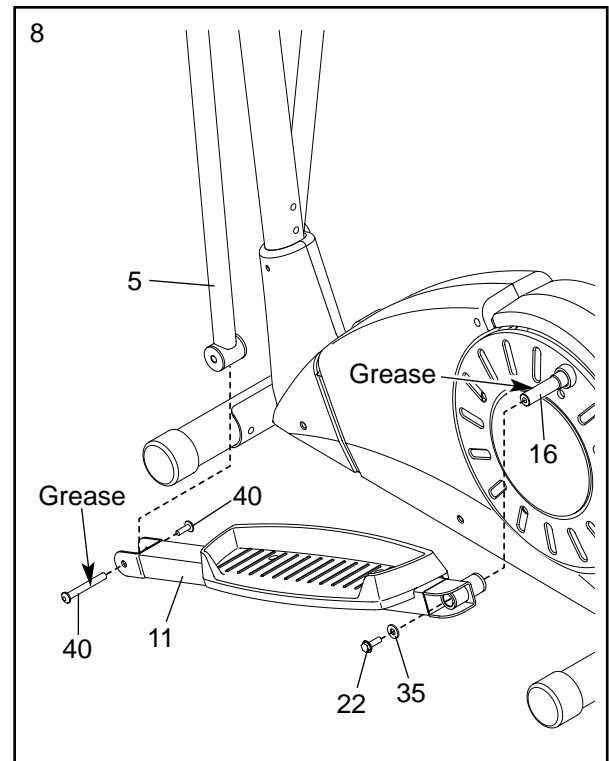

9. **Make sure that all parts of the elliptical crosstrainer are properly tightened.** Note: Some hardware may be left over after assembly is completed. To protect the floor or carpet from damage, place a mat under the elliptical crosstrainer.

HOW TO USE THE ELLIPTICAL CROSSTRAINER

HOW TO EXERCISE ON THE ELLIPTICAL CROSSTRAINER

To mount the elliptical crosstrainer, hold the handlebars and step onto the pedal that is in the lowest position. Then, step onto the other pedal. Push the pedals until they begin to move with a continuous motion. **Note: The pedal disks can turn in either direction. It is recommended that you move the pedal disks in the direction shown by the arrow; however, for variety, you may turn the pedal disks in the opposite direction.**

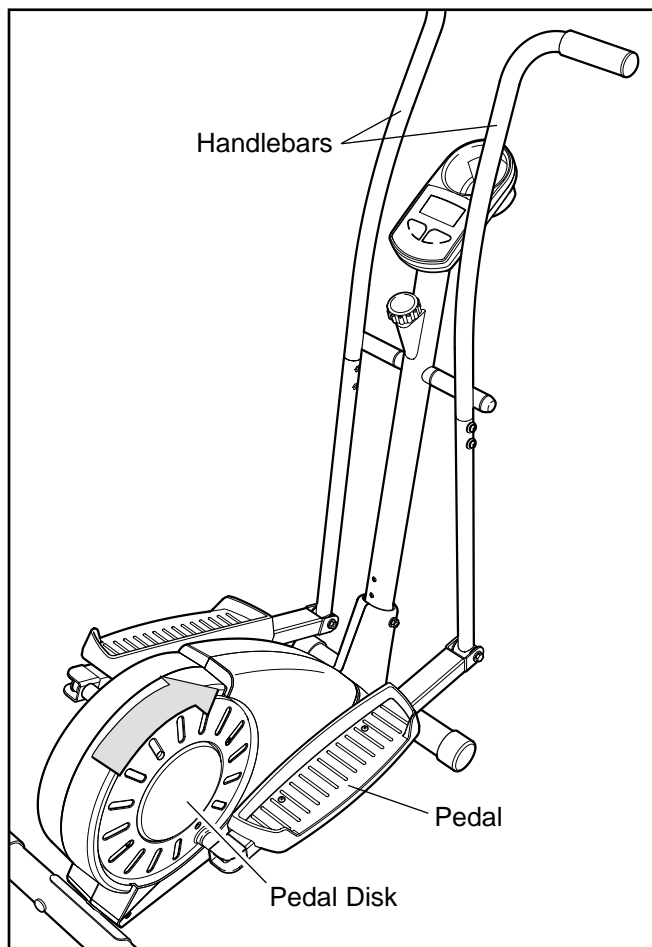

To dismount the elliptical crosstrainer, wait until the pedals come to a complete stop. **Note: The elliptical crosstrainer does not have a free wheel; the pedals will continue to move until the flywheel stops.** When the pedals are stationary, step off the highest pedal first. Then, step off the lowest pedal.

HOW TO ADJUST THE PEDALING RESISTANCE

As you exercise, you can adjust the resistance of the pedals with the resistance knob on the upright. To increase the resistance, turn the knob clockwise; to decrease the resistance, turn the knob counterclockwise.

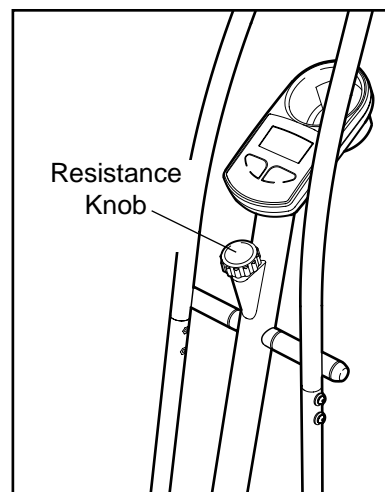

FEATURES OF THE CONSOLE

The easy-to-use console features five modes that provide instant exercise feedback during your workouts. The modes are described below.

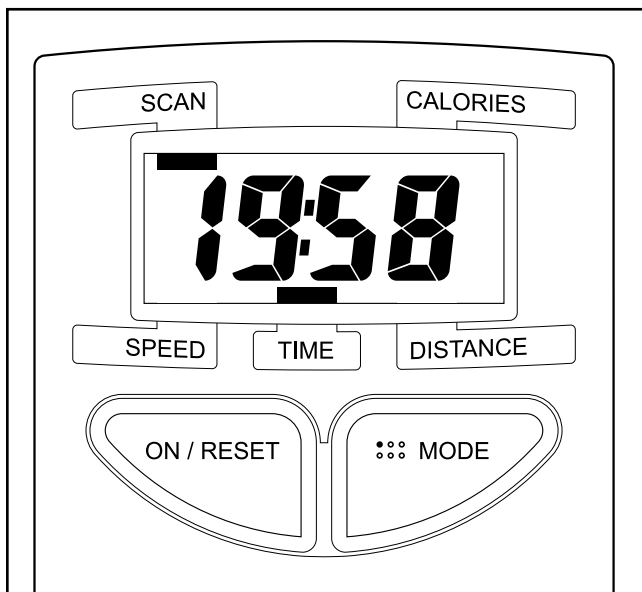

Speed—This mode displays your pedaling speed, in miles per hour or kilometers per hour.

Time—This mode displays the elapsed time. Note: If you stop pedaling for a few seconds, the time mode will pause.

Distance—This mode displays the distance you have pedaled, in miles or kilometers.

Calorie—This mode displays the approximate number of calories you have burned.

Scan—This mode displays the speed, time, distance, and calorie modes, for a few seconds each, in a repeating cycle.

HOW TO OPERATE THE CONSOLE

Make sure there are batteries in the console (see BATTERY REPLACEMENT on page 11). If there is a thin sheet of clear plastic on the console, remove it.

Follow the steps below to operate the console.

1. To turn on the power, press the On/Reset button or begin pedaling. The entire display will briefly appear; the console will then be ready for use.

2. Select one of the modes:

Scan mode—When the power is turned on, the scan mode will be selected automatically. A mode indicator will appear below the word “SCAN” to show that the scan mode is selected, and a second mode indicator will show which mode is currently displayed. Note: If you have selected a different mode, repeatedly press the Mode button to reselect the scan mode.

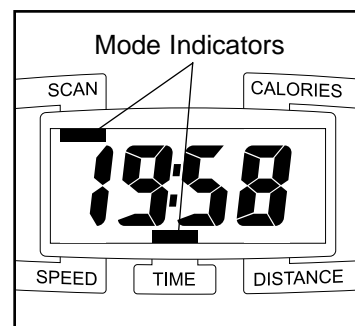

Speed, time, distance, or calorie mode—To select one of these modes for continuous display, repeatedly press the Mode button. The mode indicators will show which mode is selected. Make sure there is not a mode indicator below the word “SCAN.”

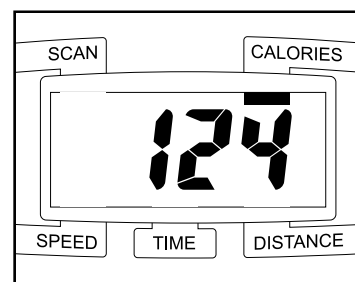

Note: The console can display speed and distance in either miles or kilometers. To change the unit of measurement, press the On/Reset button for about five seconds. The letters mph or km/h will appear in the display to show which unit of measurement is selected. When the batteries are replaced, it may be necessary to reselect the desired unit of measurement.

3. To reset the display at any time, press the On/Reset button.

4. To turn off the power, simply wait for a few minutes. **The console has an “auto-off” feature. If the pedals are not moved and the console buttons are not pressed for a few minutes, the power will turn off automatically to save the batteries.**

MAINTENANCE AND TROUBLESHOOTING

Inspect and tighten all parts of the elliptical crosstrainer regularly. Replace any worn parts immediately.

To clean the elliptical crosstrainer, use a damp cloth and a small amount of mild soap. **Important: Keep liquids away from the console, place only a sealed water bottle in the water bottle holder, and keep the console out of direct sunlight. During storage, remove the batteries from the console.**

BATTERY REPLACEMENT

If the console display becomes dim, the batteries should be replaced; most console problems are the result of low batteries. To replace the batteries, refer to step 4 on page 6 and remove the console from the upright. Next, refer to step 3 on page 6 and insert three batteries into the console. Reattach the console to the upright, being careful not to pinch the wires.

HOW TO ADJUST THE REED SWITCH

If the console does not display correct feedback, the reed switch should be adjusted. To adjust the reed switch, you must remove the Left Pedal Arm (11) and the Left Side Shield (3).

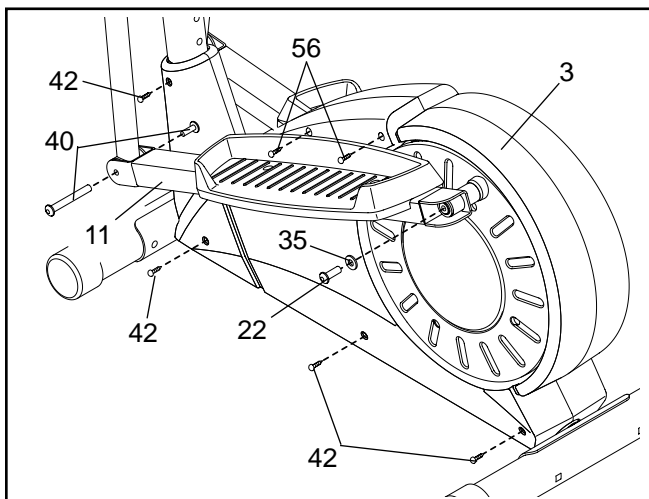

Remove the Pedal Arm Bolt Set (40), the M10 x 25mm Patch Screw (22), and the M10 Washer (35) from the Left Pedal Arm (11). Remove the Left Pedal Arm. Next, remove the two M4 x 25mm Screws (56) and the four M4 x 16mm Screws (42) from the Left Side Shield (3).

Refer to the drawing below and locate the Reed Switch (53). Loosen, but do not remove, the indicated M4 x 16mm Screw (42). Slide the Reed Switch slightly toward or away from the Magnet (58) on the flywheel. Retighten the Screw. Turn the left Pedal Disc (15) for a moment. Repeat until the console displays correct feedback. When the Reed Switch is correctly adjusted, reattach the Left Side Shield (3) and the Left Pedal Arm (11).

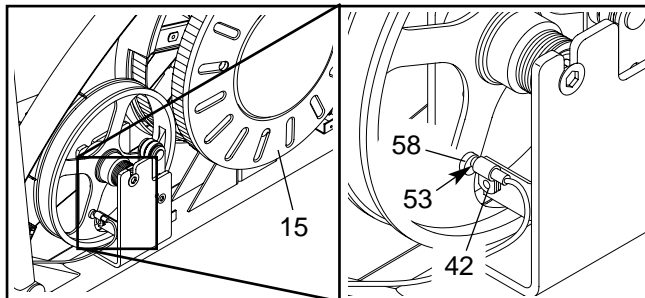

HOW TO ADJUST THE DRIVE BELT

If the pedals slip while you are pedaling, even when the resistance is adjusted to the highest setting, the Drive Belt (19) may need to be adjusted. To adjust the Drive Belt, you must first remove the left side shield. Refer to HOW TO ADJUST THE REED SWITCH at the left and remove the left side shield.

Next, loosen the M8 x 22mm Flat Head Screw (41) and turn the Idler Adjustment Bolt (62) until the Drive Belt (19) is tight. When the Drive Belt is tight, tighten the Flat Head Screw. Reattach the left side shield.

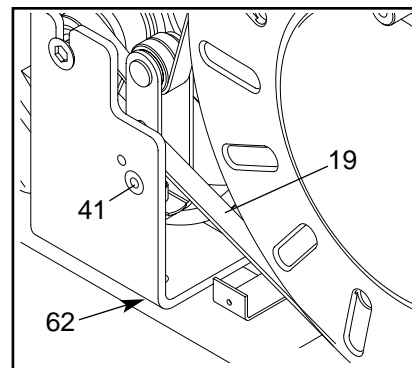

HOW TO ADJUST THE RESISTANCE STRAP

If the resistance knob is turned to the highest setting and there is not enough pedaling resistance, the resistance strap can be adjusted. To adjust the resistance strap, first remove the left side shield (see HOW TO ADJUST THE REED SWITCH on page 11).

Next, turn the resistance knob to the lowest setting. Open the Strap Clamp (26) and pull the end of the Resistance Strap (18) downward slightly. Close the Strap Clamp and turn the Flywheel (17) to make sure that there is not too much resistance.

When the resistance strap is properly adjusted, re-attach the left side shield and the left pedal arm.

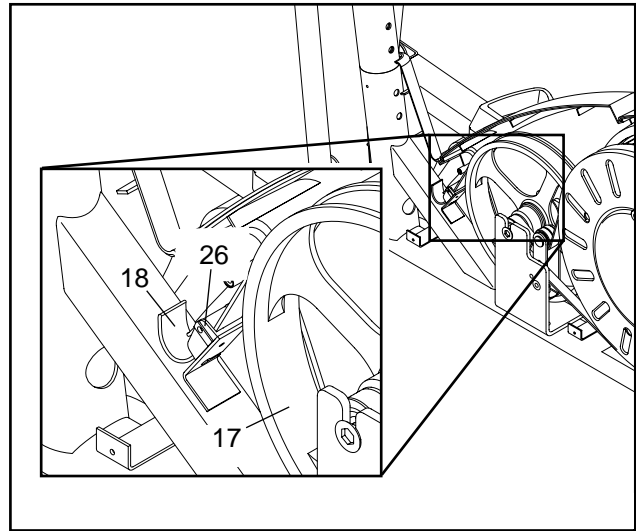

CONDITIONING GUIDELINES

The following guidelines will help you to plan your exercise program. Remember that proper nutrition and adequate rest are essential for successful results.

⚠ WARNING: Before beginning this or any exercise program, consult your physician. This is especially important for persons over the age of 35 or persons with pre-existing health problems.

EXERCISE INTENSITY

Whether your goal is to burn fat or to strengthen your cardiovascular system, the key to achieving the desired results is to exercise with the proper intensity. The proper intensity level can be found by using your heart rate as a guide. The chart below shows recommended heart rates for fat burning, maximum fat burning, and cardiovascular (aerobic) exercise.

165	155	145	140	130	125	115	♥
145	138	130	125	118	110	103	♥
125	120	115	110	105	95	90	♥
20	30	40	50	60	70	80	

To find the proper heart rate for you, first find your age at the bottom of the chart (ages are rounded off to the nearest ten years). Next, find the three numbers above your age. The three numbers are your “training zone.” The lowest number is the recommended heart rate for fat burning; the middle number is the recommended heart rate for maximum fat burning; the highest number is the recommended heart rate for aerobic exercise.

Fat Burning

To burn fat effectively, you must exercise at a relatively low intensity level for a sustained period of time. During the first few minutes of exercise, your body uses easily accessible *carbohydrate* calories for energy. Only after the first few minutes of exercise does your body begin to use stored *fat* calories for energy. To burn fat, adjust the intensity of your exercise until your heart rate is between the lower two numbers in your training zone as you exercise.

Aerobic Exercise

If your goal is to strengthen your cardiovascular system, your exercise must be “aerobic.” Aerobic exercise is activity that requires large amounts of oxygen for prolonged periods of time. This increases the demand on the heart to pump blood to the muscles, and on the lungs to oxygenate the blood. For aerobic exercise, adjust the intensity of your exercise until your heart rate is near the highest number in your training zone.

HOW TO MEASURE YOUR HEART RATE

Exercise for at least four minutes. Then, stop exercising and place two fingers on your wrist as shown. Take a six-second heartbeat count, and multiply the result by 10 to find your heart rate. For example, if your six-second heartbeat count is 14, your heart rate is 140 beats per minute. (A six-second count is used because your heart rate will drop rapidly when you stop exercising.)

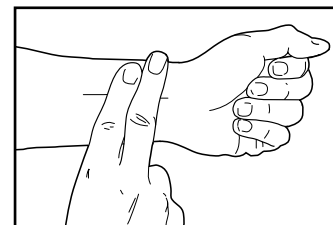

WORKOUT GUIDELINES

Each workout should include the following three parts:

A warm-up, consisting of 5 to 10 minutes of stretching and light exercise. A proper warm-up increases your body temperature, heart rate, and circulation in preparation for exercise.

Training zone exercise, consisting of 20 to 30 minutes of exercising with your heart rate in your training zone. Note: During the first few weeks of your exercise program, do not keep your heart rate in your training zone for longer than 20 minutes.

A cool-down, with 5 to 10 minutes of stretching. This will increase the flexibility of your muscles and will help to prevent post-exercise problems.

EXERCISE FREQUENCY

To maintain or improve your condition, plan three workouts each week, with at least one day of rest between workouts. After a few months of regular exercise, you may complete up to five workouts each week, if desired. The key to success is make exercise a regular and enjoyable part of your everyday life.

PART LIST—Model No. WLEL28020

R0802A

Key No.	Qty.	Description	Key No.	Qty.	Description
1	1	Frame	34	4	M10 x 75mm Carriage Bolt
2	1	Upright	35	2	M10 Washer
3	1	Left Side Shield	36	4	M6 x 54mm Flat Head Bolt
4	1	Right Side Shield	37	4	Pedal Arm Bushing
5	2	Handlebar Arm	38	5	M8 Nylon Locknut
6	1	Left Handlebar	39	2	M10 Washer
7	1	Idler Assembly	40	2	Pedal Arm Bolt Set
8	1	Right Handlebar	41	1	M8 x 22mm Flat Head Screw
9	1	Hook	42	15	M4 x 16mm Screw
10	1	Front Stabilizer	44	1	Upper Wire
11	1	Left Pedal Arm	45	1	Resistance Control/Cable
12	1	Right Pedal Arm	46	2	Handlebar Cap
13	2	Pedal	47	2	Handlebar Spacer
14	2	Axle Cap	48	2	M10 x 66mm Button Bolt
15	2	Pedal Disc	49	4	Small Handlebar Bushing
16	2	Disc Crossbar	50	4	M8 x 38mm Button Bolt
17	1	Flywheel	51	8	M6 x 35mm Screw
18	1	Resistance Strap	52	1	M4 x 16mm Flat Head Screw
19	1	Drive Belt	53	1	Reed Switch/Wire
20	1	Cable Clamp	54	1	Cable Clamp
21	4	Endcap	55	1	Lower Cable
22	2	M10 x 25mm Patch Screw	56	2	M4 x 25mm Screw
23	1	Console	57	1	M10 Flat Head Bolt
24	2	Handgrip	58	1	Magnet
25	4	M6 Washer	59	2	M10 Split Washer
26	1	Strap Clamp	60	4	Large Handlebar Bushing
27	4	M6 Nylon Locknut	61	2	5/16" x 25.4mm Hex Bolt
28	1	Rear Stabilizer	62	1	Idler Adjustment Bolt
29	2	Flywheel Bearing	63	1	Resistance Knob/Cable
30	2	Large Snap Ring	#	1	Allen Wrench
31	2	Large Bearing	#	1	Grease
32	1	Pedal Axle	#	1	User's Manual
33	7	M10 Nylon Locknut			

Note: # indicates a non-illustrated part. Specifications are subject to change without notice.

EXPLODED DRAWING—Model No. WLEL28020

R0802A

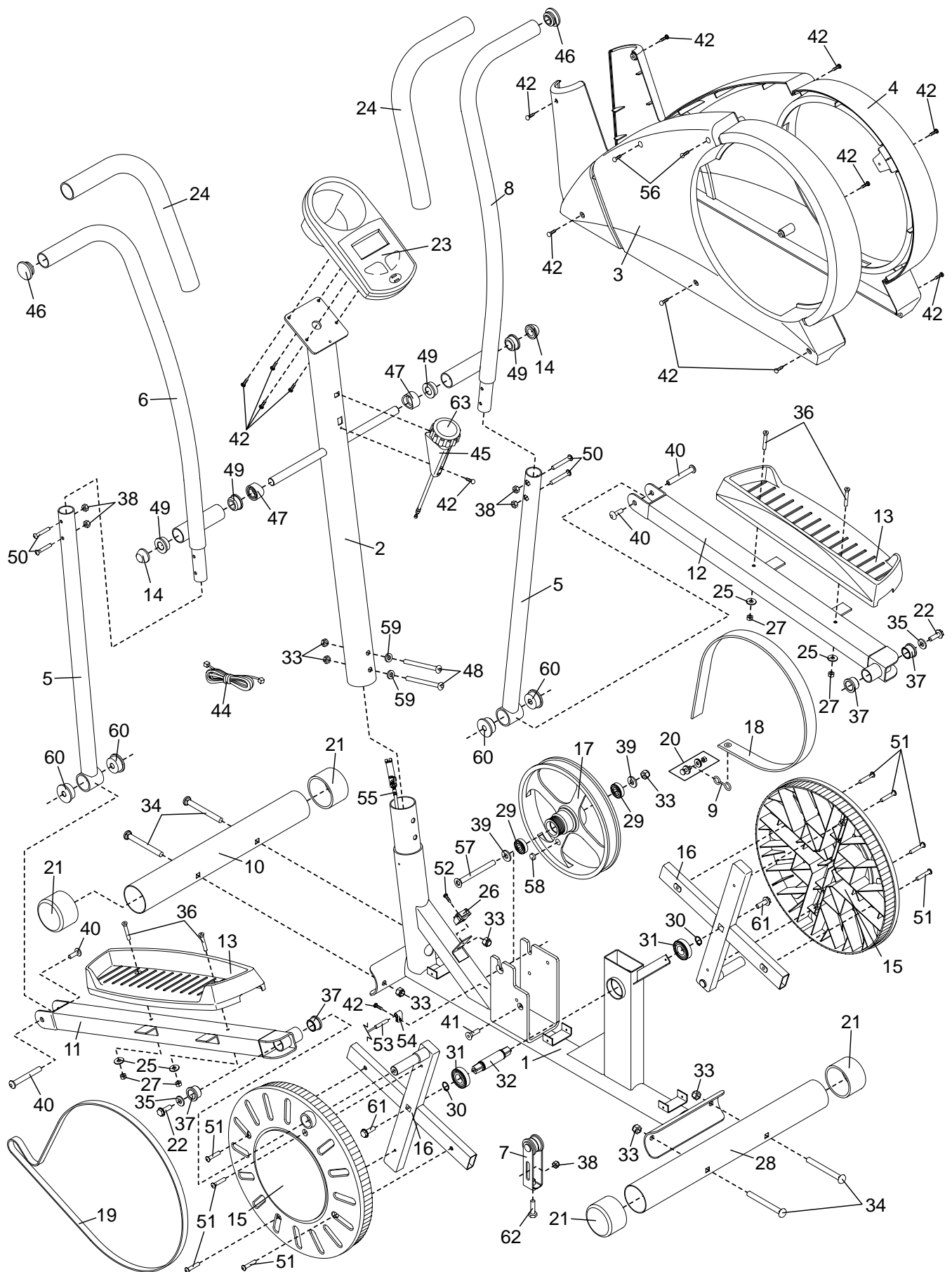

HOW TO ORDER REPLACEMENT PARTS

To order replacement parts, simply call our Customer Service Department toll-free at 1-800-999-3756, Monday through Friday, 6 a.m. until 6 p.m. Mountain Time (excluding holidays). To help us assist you, please be prepared to give the following information when calling:

- The MODEL NUMBER of the product (WLEL28020)
- The NAME of the product (WESLO® MOMENTUM 750 elliptical crosstrainer)
- The SERIAL NUMBER of the product (see the front cover of this manual)
- The KEY NUMBER and DESCRIPTION of the part(s) (see page 14)

LIMITED WARRANTY

ICON Health & Fitness, Inc. (ICON), warrants this product to be free from defects in workmanship and material, under normal use and service conditions, for a period of ninety (90) days from the date of purchase. This warranty extends only to the original purchaser. ICON's obligation under this warranty is limited to replacing or repairing, at ICON's option, the product through one of its authorized service centers. All repairs for which warranty claims are made must be pre-authorized by ICON. This warranty does not extend to any product or damage to a product caused by or attributable to freight damage, abuse, misuse, improper or abnormal usage or repairs not provided by an ICON authorized service center; products used for commercial or rental purposes; or products used as store display models. No other warranty beyond that specifically set forth above is authorized by ICON.

ICON is not responsible or liable for indirect, special or consequential damages arising out of or in connection with the use or performance of the product or damages with respect to any economic loss, loss of property, loss of revenues or profits, loss of enjoyment or use, costs of removal or installation or other consequential damages of whatsoever nature. Some states do not allow the exclusion or limitation of incidental or consequential damages. Accordingly, the above limitation may not apply to you.

The warranty extended hereunder is in lieu of any and all other warranties and any implied warranties of merchantability or fitness for a particular purpose is limited in its scope and duration to the terms set forth herein. Some states do not allow limitations on how long an implied warranty lasts. Accordingly, the above limitation may not apply to you.

This warranty gives you specific legal rights. You may also have other rights which vary from state to state.

ICON HEALTH & FITNESS, INC., 1500 S. 1000 W., LOGAN, UT 84321-9813